



**Thick Film Chip Resistors Arrays
(Lead-Free for CN 0 ohm Series)
Halogen-Free**

Document No.	TCN-XX0S036C
Revise Date	2014/04/25
page number	1/10

1. Scope :

This specification applies for the CN 0 ohm series of thick film chip resistor arrays made by TA-I.

2. Construction , Dimensions , Schematic :

2.1 Construction :

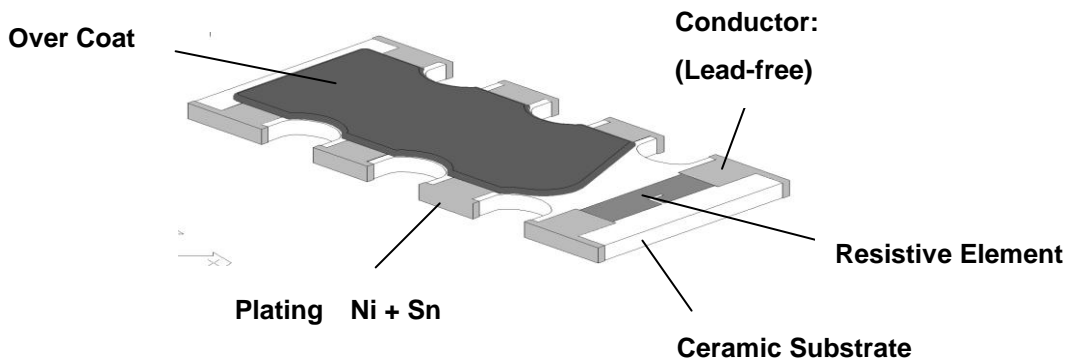

2.1.1 Chip Resistor Arrays :

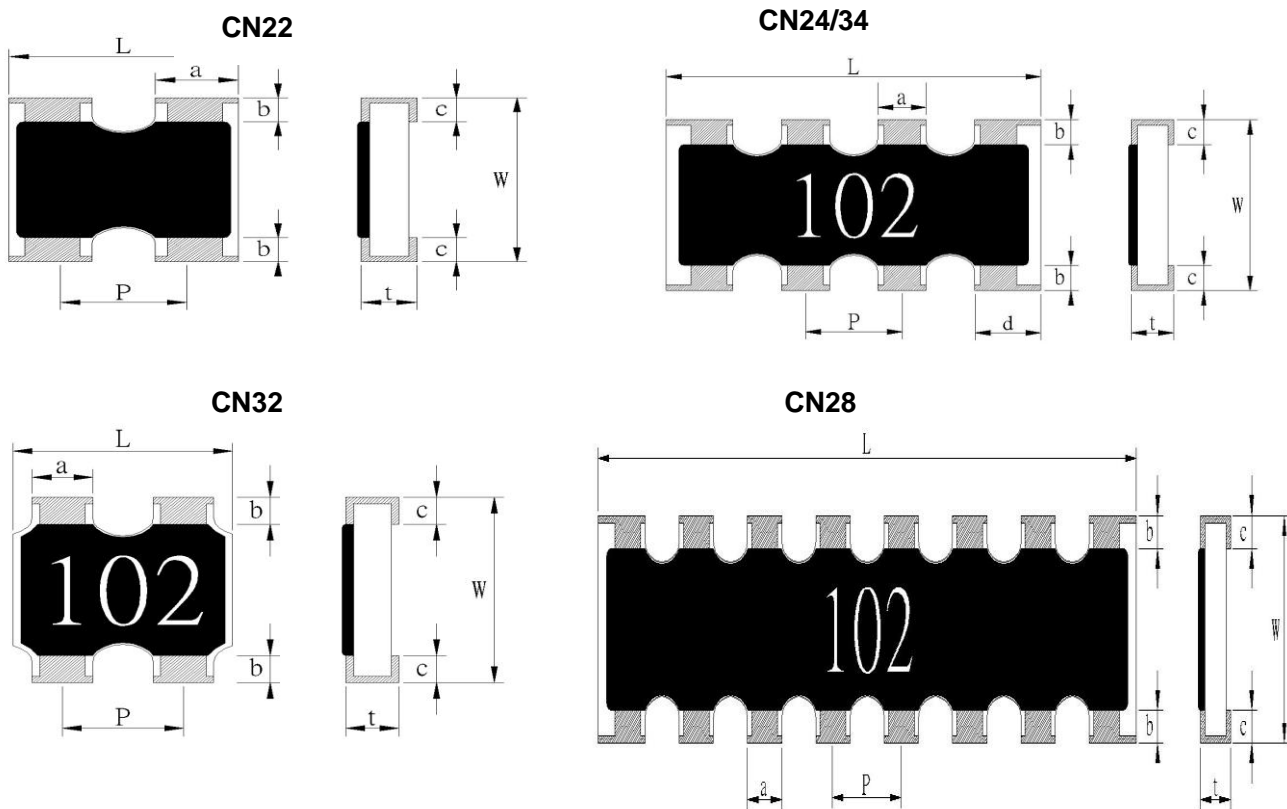



**Thick Film Chip Resistors Arrays
(Lead-Free for CN 0 ohm Series)
Halogen-Free**

Document No.	TCN-XX0S036C
Revise Date	2014/04/25
page number	2/10

2.2 Dimension :

UNIT: mm

Type	L	W	t	P	a	b	c	d
CN22	1.0 ± 0.1	1.0 ± 0.1	0.35 ± 0.1	0.65 ± 0.1	0.33 ± 0.1	0.15 ± 0.1	0.25 ± 0.1	0.33±0.1
CN24	2.0 ± 0.1	1.0 ± 0.1	0.4 ± 0.1	0.5 ± 0.05	0.3 ± 0.1	0.15 ± 0.1	0.25 ± 0.1	0.4±0.1
CN28	4.0 ± 0.2	1.6 ± 0.15	0.4 ± 0.1	0.5 ± 0.05	0.3 ± 0.1	0.25 ± 0.1	0.25 ± 0.1	0.4±0.1
CN32	1.6 ± 0.15	1.6 ± 0.15	0.45 ± 0.1	0.76 ± 0.1	0.45 ± 0.1	0.3 ± 0.2	0.3 ± 0.2	0.45±0.1
CN34	3.2 ± 0.2	1.6 ± 0.15	0.5 ± 0.1	0.8 ± 0.05	0.45 ± 0.1	0.3 ± 0.2	0.3 ± 0.2	0.6±0.1

2.3 Schematic :

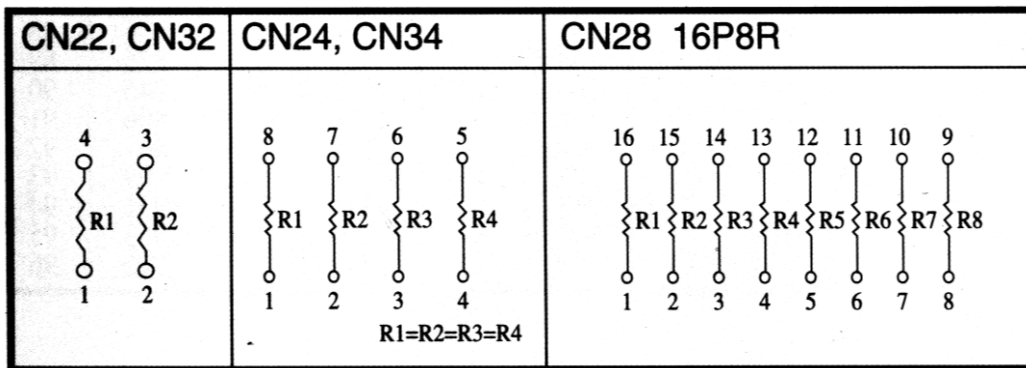



**Thick Film Chip Resistors Arrays
(Lead-Free for CN 0 ohm Series)
Halogen-Free**

Document No.	TCN-XX0S036C
Revise Date	2014/04/25
page number	3/10

**3. Type Designation :
3.1 Chip Resistor Arrays**

<u>CN</u>	<u>24</u>	<u>J</u>	<u>TN</u>	<u>0</u>
Product Code CN : Chip Resistor Array	size Power Rating	Tolerance	Packaging	Nominal Resistance
22-0402*2 24-0402*4 28-0402*8 32-0603*2 34-0603*4	J-±5% G-±2% F-±1%	T- Paper Tape N : Lead-free	1 digits E.G.: (E-24) 0 = 0Ω	

Note :

TN : Lead-Free products packaged by paper tape

4. Ratings & Characteristics :

0Ω THICK FILE CHIP RESISTOR ARRAYS			
Type	Rate Current	Max Overload Current	Resistance Range
CN Series	1A	2.5A	50mΩ MAX



**Thick Film Chip Resistors Arrays
(Lead-Free for CN 0 ohm Series)
Halogen-Free**

Document No.	TCN-XX0S036C
Revise Date	2014/04/25
page number	4/10

4.1 Derating Curve :

For resistors operated at ambient temperature over 70°C , power rating shall be derated in accordance with figure 1.

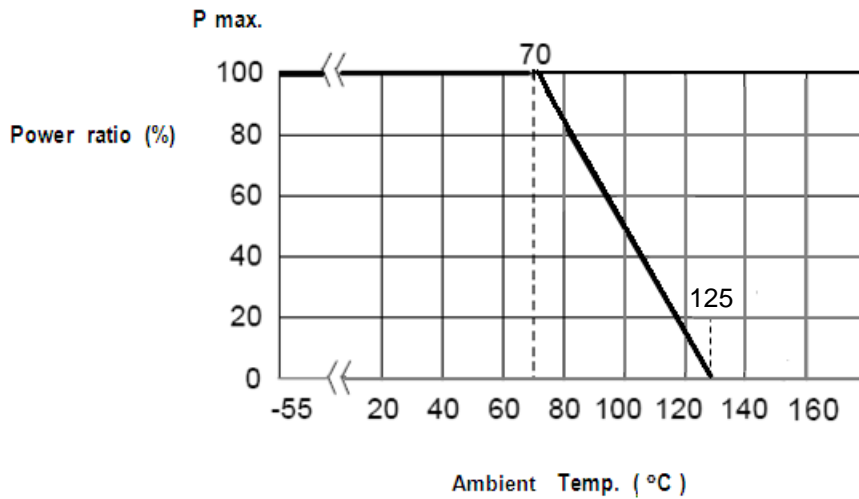

Figure 1

4.2 Rated Voltage:

The rated voltage is calculated by the following formula:

$$E = \sqrt{P * R}$$

E=Rated Voltage(V)

P=Rated Power(W)

R=Resistance Value(Ω)



**Thick Film Chip Resistors Arrays
(Lead-Free for CN 0 ohm Series)
Halogen-Free**

Document No.	TCN-XX0S036C
Revise Date	2014/04/25
page number	5/10

5. Reliability Tests:

Test Items	Reference standard	Condition of Test	Test Limits (ΔR)
Temperature Coefficient of Resistance	IEC60115-1-4.8 JIS-C5201-1-4.8	-55~ +125 °C	Refer 4.0
Short Time Overload	IEC60115-1-4.13 JIS-C5201-1-4.13	2.5 X rated voltage for 5 sec	50 m Ω or less
Intermittent Overload	IEC60115-1-4.39 JIS-C5201-1-4.39	2.5X rated voltage or Max Overloading Voltage , 1 sec "ON" 25 sec "OFF" , 10000 cycles	50m Ω or less
Load Life	IEC60115-1-4.25.1 JIS-C5201-1-4.25.1	1000 hours at rated voltage , 70°C , 1.5hours "ON " , 0.5hour "OFF"	100 m Ω or less
Load Life with Humidity	IEC60115-1-4.24 JIS-C5201-1-4.24	1000 hours at rated voltage , 40 \pm 2°C , 90~95% RH 1.5hours "ON " , 0.5hour "OFF"	100 m Ω or less
Rapid Change of Temperature	IEC60115-1-4.19 JIS-C5201-1-4.19	-55°C (30 min.) / +155 °C (30 min.) 5 cycles	50 m Ω or less
Solderability	IEC60115-1-4.17 JIS-C5201-1-4.17	245 \pm 5°C solder, 2 \pm 0.5 sec dwell. Solder : Sn96.5 / Ag3.0 / Cu0.5	At least 95% of surface area of electrode shall be covered with new solder.
Core body	IEC60115-1-4.15 JIS-C5201-1-4.15	Pressure 1.0 kgf a R0.5 pressure rod for 10 sec	Without mechanical damage such as breaks. Electrical characteristics shall be satisfied
Dielectric Withstanding Voltage (Voltage Proof)	IEC60115-1-4.7 JIS-C5201-1-4.7	Applying voltage 100V for 1 minute.	No abnormalities such as flashover, burning dielectric breakdown shall appear.
Resistance to Solder Heat	IEC60115-1-4.18 JIS-C5201-1-4.18	270 \pm 5°C solder , 10 \pm 1 sec dwell .	50m Ω or less

Note* : RCWV : Rated continuous working voltage .



**Thick Film Chip Resistors Arrays
(Lead-Free for CN 0 ohm Series)
Halogen-Free**

Document No.	TCN-XX0S036C
Revise Date	2014/04/25
page number	6/10

6. Marking

6.1 1 digit, e.g.,:(E-24)
0 = 0Ω.

6.2 No Marking for CN22

7. Taping & Reel

7.1 Taping Dimensions

7.1.1 2 mm pitch paper

UNIT: mm

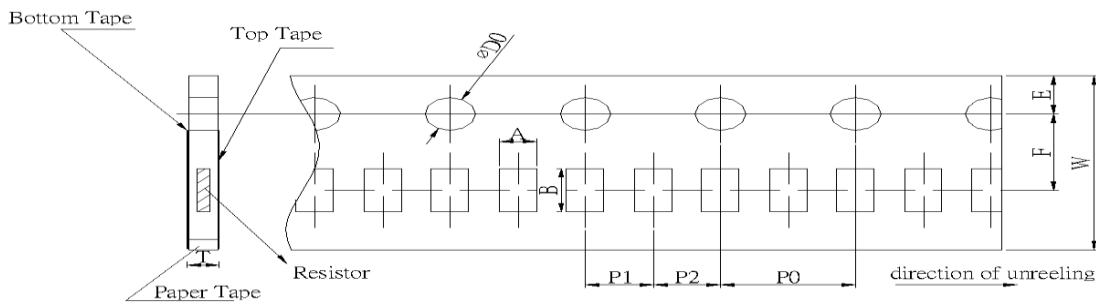

Type	A	B	W	F	E	P1	P2	P0	φ D0	T0
CN22	1.2±0.15	1.2±0.1	8.0±0.2	3.5±0.05	1.75±0.1	2.0±0.1	2.0±0.05	4.0±0.1	1.5	0.45±0.1
CN24		2.2±0.2								0.64±0.1

7.1.2 4 mm pitch paper

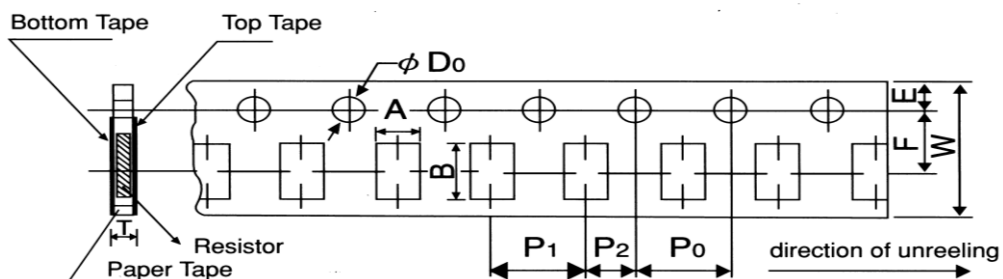

UNIT: mm

Type	A	B	W	F	E	P1	P2	P0	φ D0	T
CN28	1.9±0.2	4.3±0.2	8.0±0.2	3.5±0.05	1.75±0.1	4.0±0.1	2.0±0.05	4.0±0.1	1.5	0.84±0.1
CN32	1.8±0.2	1.8±0.2								
CN34	2.0±0.15	3.6±0.2								



**Thick Film Chip Resistors Arrays
(Lead-Free for CN 0 ohm Series)
Halogen-Free**

Document No.	TCN-XX0S036C
Revise Date	2014/04/25
page number	7/10

Package Type	Paper Tape			
	4 mm pitch		2 mm pitch	
	178mm/R	250mm/R	178mm/R	250mm/R
CN22			10000	20000
CN24			10000	20000
CN28	5000			
CN32	5000			
CN34	5000	10000		

7.2 Reel Specifications

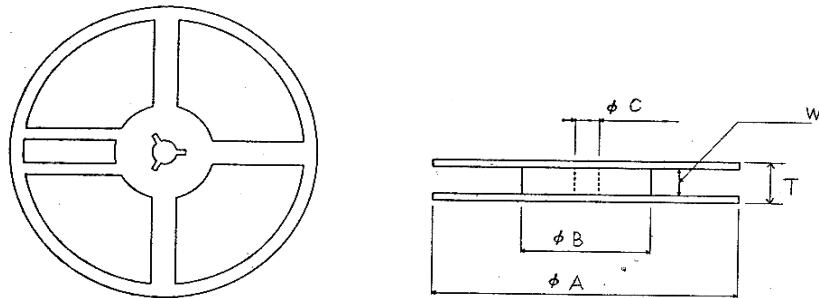

UNIT: mm

Type	ϕA	ϕB	ϕC	W	T
CN22/24/28 CN32/34	178.0 ± 2.0	60.0 ± 1.0	13.0 ± 1.0	9.0 ± 1.0	11.5 ± 1.0

7.3 Peel off Strength:

Peel-off force of paper and blister tape is in accordance with "JIS-C5202" that is, 0.1 to 0.7 N at a peel-off speed of 300 mm / minute.

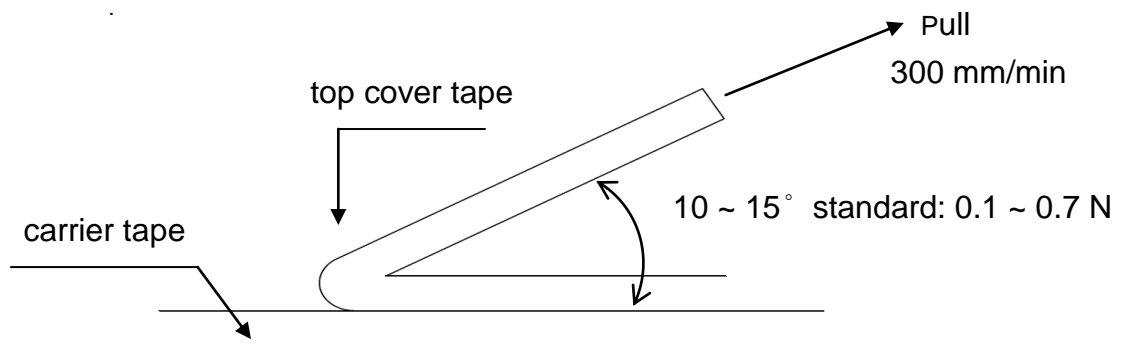



**Thick Film Chip Resistors Arrays
(Lead-Free for CN 0 ohm Series)
Halogen-Free**

Document No.	TCN-XX0S036C
Revise Date	2014/04/25
page number	8/10

8. Label

8.1 Manufacture Label :

8.1.1 Chip Resistor Array

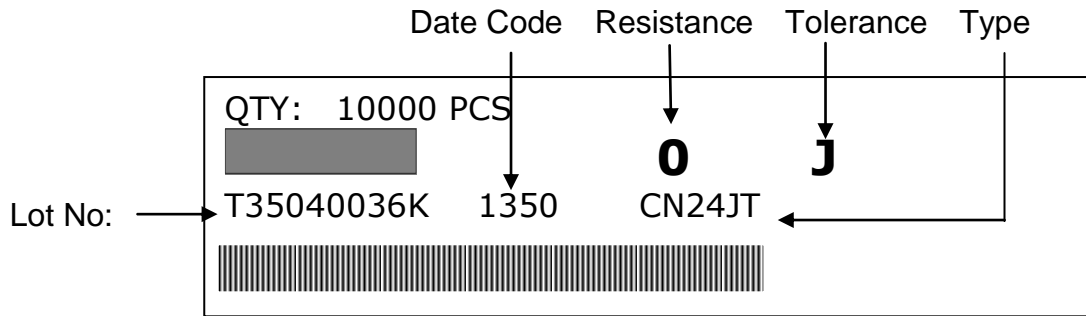

8.2. Customer Label (By customer request):

8.2.1 Chip Resistor Array

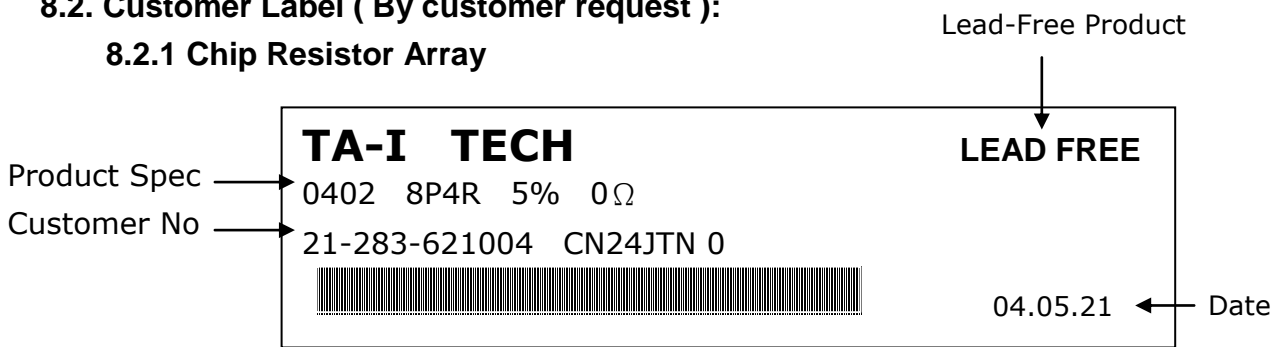

9. Recommended land patterns :

9.1 CN22,CN32,CN34

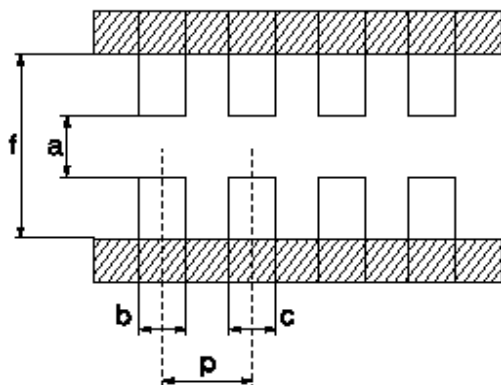

Type	Land pattern Size	Dimension (mm)				
		a	b	c	p	f
CN	22	0.5	0.35~0.4	0.35~0.4	0.65	1.4~1.5
CN	32	0.7~0.9	0.4~0.5	0.4~0.5	0.8	2.2~2.6
CN	34	0.7~0.9	0.4~0.5	0.4~0.5	0.8	2.2~2.6



**Thick Film Chip Resistors Arrays
(Lead-Free for CN 0 ohm Series)
Halogen-Free**

Document No.	TCN-XX0S036C
Revise Date	2014/04/25
page number	9/10

9.2 CN24 , CN28

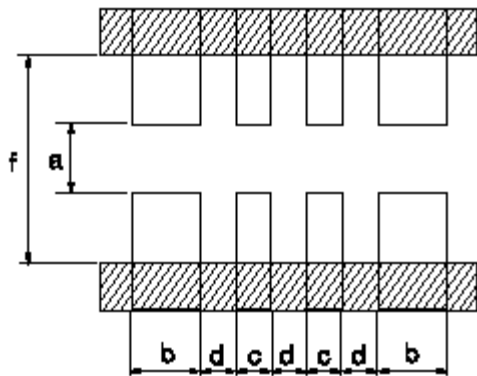

Type	Size	Land pattern	Dimension (mm)				
			a	b	c	d	f
CN	24		0.4	0.525	0.25	0.25	1.4
CN	28		1.0	0.425	0.25	0.25	2.0

10. Recommend IR – Reflow profile : (solder : Sn96.5 / Ag3 / Cu0.5)

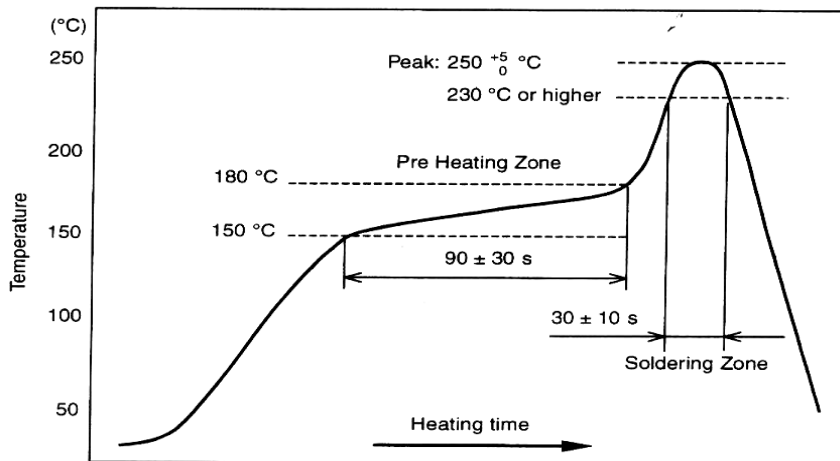

Peak : 250 ⁺⁵/₋₀ °C , 5 sec
 Pre – heat Zone : 150 to 180 °C , 90 ± 30 sec
 Soldering Zone : 230°C or higher , 30 ± 10 sec



**Thick Film Chip Resistors Arrays
(Lead-Free for CN 0 ohm Series)
Halogen-Free**

Document No.	TCN-XX0S036C
Revise Date	2014/04/25
page number	10/10

11. Storage Conditions:

Temperature : 5 to 35 °C

Related Humidity :40 to 75% RH

12. Shelf Life :

2 Years from manufacturing date.

13. ECN :

Engineering Change Notice: The customer will be informed with ECN if there is significant modification on the characteristics and materials described in Approval Sheet.

14. Manufacturing Country & City :

TA-I TECHNOLOGY CO., LTD. (Taiwan– Tao Yuan)

Tel: 886-3-3246169 Fax : 886-3-3246167

Associated companies :

(1) FORTUNE TASK RESISTOR FACTORY (China – Dongguan)

Tel : 86-769-8339-4790~3 Fax : 86-769-8339-4794

(2) TA-I TECHNOLOGY (DONGGUAN) CO., LTD. (China –Dongguan)

Tel : 86-769-8339-4790~3 Fax : 86-769-8339-4794

(3) TA-I TECHNOLOGY (SU ZHOU) CO., LTD. (China – Su Zhou)

Tel :86- 512-63457879 Fax : 86-512-63457869

(4) TAI OHM ELECTRONICS (M) SDN. BHD. (Malaysia – Pulaupinang)

Tel :604- 3900480 Fax : 604-3901481

(5) P.T.TAI ELECTRONICS Indonesia (Indonesia – Jakarta)

Tel :62-21-89830123 Fax : 62-21-89830703